



INVERTER SERIES

V1000



GB

D
E
F
I

V1000
V1000
V1000
V1000

V1000

YASKAWA INVERTER DRIVE TECHNOLOGY

Contents

- ▶ **Page 2**
Experience & Innovation
A leader in Inverter Drives technology
V1000 – Easy and cost-saving handling through all kinds of applications
- ▶ **Page 3**
"One for all" – Multiple Applications
- ▶ **Page 4/5**
Specifications
- ▶ **Page 6**
Connection Diagram
- ▶ **Page 7**
V1000 Dimensions
- ▶ **Page 8**
V1000 Finless Version Dimensions
- ▶ **Page 9**
V1000 IP66 Dimensions
- ▶ **Page 10**
Options
- ▶ **Page 11**
Ratings & Type Descriptions incl. finless

Experience & Innovation

For more than 90 years YASKAWA has been manufacturing and supplying mechatronic products for machine building and industrial automation. Its standard products as well as tailor-made solutions are famous and have a high reputation for outstanding quality and durability.

A leader in Inverter Drives technology

Extensive research and development has allowed YASKAWA to remain at the forefront of motion control and automation technology. This technological leadership has helped to modernise industries such as mining, steel, pulp and paper, chemical, automotive, packaging, machine tool and semiconductor.

In 2007 YASKAWA produced its 10 millionth inverter in the new inverter plant in Yukuhashi, Japan. By this YASKAWA is probably the biggest inverter manufacturer in the world.

The 10 millionth inverter was a V1000, the latest inverter developed by YASKAWA. Awarded by IEN magazine as being the 'most innovative product 2007' at Hanover Fair Industry 2007 the V1000 has raised the bar in the market in terms of usability and reliability.

V1000 – Easy and cost-saving handling through all kinds of applications

This powerful little helper sets standards in terms of user friendliness and process orientation. The development of the V1000

focuses on all aspects of application, installation, operation and maintenance.

Safety Integrated

YASKAWA V1000 is one of the first general purpose compact drives with built-in two channel hardware base block input. It already meets international safety standards and thereby supports machine builder to apply to international machine directives.

Finless Type

YASKAWA has as one of the first manufacturers promoted the development of finless type inverters for the European and international markets. Consequently the V1000 is available as finless version for applications with an external cooling system.

YASKAWA V1000 Features

- ▶ Dual Safety Input, safety category 3 (EN954-1) and stop category 0 (EN60204-1) and IEC-61508 SIL2
- ▶ In normal duty (120% overload) one frame size larger motor can be driven
- ▶ Standard AC Motor and PM motor control
- ▶ V/f and open-loop current vector control
- ▶ One of the smallest inverter drives in the world
- ▶ Side-by-side mounting
- ▶ Icon-based programming
- ▶ Designed for 10 years of maintenance-free operation



“One for all” – Multiple Applications

YASKAWA V1000 is a general purpose inverter drive covering the demands of a wide field of applications. Simple duties as well as requirements of complex systems need a higher level of functionality, reliability and easy handling, which are provided by the V1000.

- ▶ For energy saving, permanent magnet motor control is possible
- ▶ Selectable control method: open-loop current vector or V/f
- ▶ Small Design – Big Power: 150% overload in heavy duty service is possible. For applications with low overload requirements the drive can be operated with 120% overload in normal duty service. Consequently you can use a drive of smaller size to do the work of a bigger one.
- ▶ Worldwide specification CE, UL, cUL, RoHS (TÜV safety approved)
- ▶ High flux braking reduces braking time to the half

Easy Installation

YASKAWA V1000 reduces installation time and costs. Installable in tight spaces it requires a minimum of set-up time and provides you all the comfort of a modern up-to-date inverter drive.

- ▶ One of the smallest inverter drives in the world saves mounting space and cost by side-by-side mounting
- ▶ Application parameter pre-settings shorten set-up time
- ▶ Same handling and parameter structure for all YASKAWA inverters
- ▶ DriveWorksEZ visual programming tool. Simply drag and drop icons to customize your drive. Create special sequences and detection functions, then load them onto the drive.

Quick Maintenance

YASKAWA V1000 is an inverter drive which adapts to user demands and provides maintenance functions that ensure quick replacement and minimize down time.

- ▶ Removable terminal board with parameter memory for quick and easy maintenance
- ▶ Screwless control terminal saves setup time

Reliable Operation

The V1000 continues the tradition of YASKAWA by being the reliable link in your production chain.

- ▶ Designed for Long Performance Life (10 years 24 h per day at 80% nominal load.)
- ▶ Quick response on load and speed changes improves your machine performance
- ▶ Online Auto-Tuning to optimise for improved motor performance at low speed
- ▶ Optional external 24 VDC-supply assures communication and data flow in any power-down situation
- ▶ Dual safety input: safety category 3 (EN954-1), stop category 0 and IEC-61508 SIL2

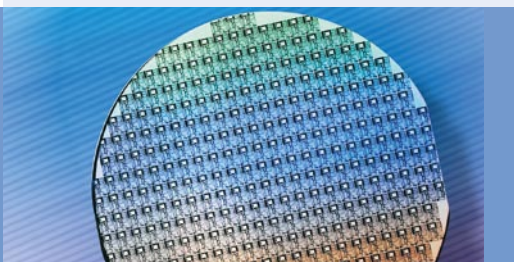

Specifications

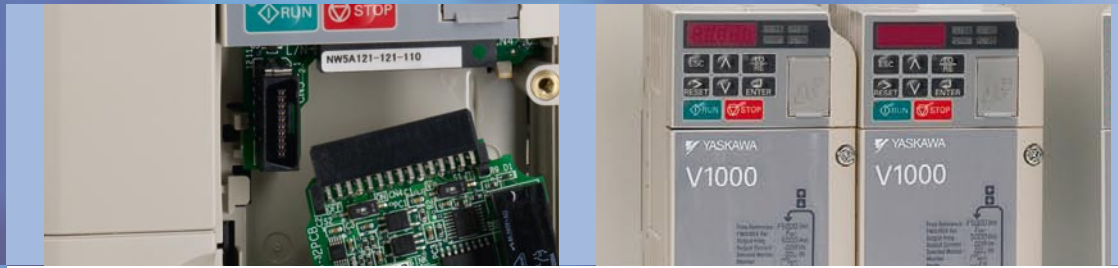

Voltage class		Single-phase 230 V						
Inverter model CIMR-VCBA*1		0001	0002	0003	0006	0010	0012	00018*6
Inverter output	Motor output kW at normal duty*2	0.18	0.37	0.75	1.1	2.2	3.0	—
	Motor output kW at heavy duty*2	0.1	0.18	0.55	0.75	1.5	2.2	4.0
	Rated output current at normal duty [A]*3	1.2	1.9	3.3	6	9.6	12	—
	Rated output current at heavy duty [A]	0.8*4	1.6*4	3.0*4	5.0*4	8.0*5	11.0*5	17.5*5
	Overload	125% for 60 sec normal duty, 150 % for 60 sec at heavy duty from inverter rated output current						
	Rated output power at normal duty [kVA]*	0.5	0.7	1.3	2.3	3.7	4.6	8.0
	Rated output power at heavy duty [kVA]*	0.3	0.6	1.1	1.9	3.0	4.2	6.7
Max. output voltage	Three-phase 200 to 240 V (proportional to input voltage)							
Max. output frequency	400 Hz							
Inverter input	Rated input voltage	Single-phase 200 to 240 V, -15% to +10%						
	Rated input frequency	50/60 Hz, ±5%						

* based on input voltage 220 V

Voltage class		Three-phase 200 V										
Inverter model CIMR-VC2A		0001	0002	0004	0006	0010	0012	0020	0030	0040	0056	0069
Inverter output	Motor output kW at normal duty*2	0.18	0.37	0.75	1.1	2.2	3.0	5.5	7.5	11.0	15.0	18.5
	Motor output kW at heavy duty*2	0.1	0.2	0.4	0.75	1.5	2.2	4.0	5.5	7.5	11.0	15.0
	Rated output current at normal duty [A]*3	1.2	1.9	3.5	6.0	9.6	12.0	19.6	30.0	40.0	56.0	69.0
	Rated output current at heavy duty [A]	0.8*4	1.6*4	3.0*4	5.0*4	8.0*5	11.0*5	17.5*5	25.0*5	33.0*5	47.0*5	60.0*5
	Overload	120% for 60 sec at normal duty, 150% for 60 sec at heavy duty from inverter rated output current										
	Rated output power at normal duty [kVA]*	0.5	0.7	1.3	2.3	3.7	4.6	7.5	11.4	15.2	21.3	26.3
	Rated output power at heavy duty [kVA]*	0.3	0.6	1.1	1.9	3.0	4.2	6.7	9.5	12.6	17.9	22.9
Max. output voltage	Three-phase 200 to 240 V (proportional to input voltage)											
Max. output frequency	400 Hz											
Inverter input	Rated input voltage	Three-phase 200 to 240 V, -15% to +10%										
	Rated input frequency	50/60 Hz, ±5%										

* based on input voltage 220V

Voltage class		Three-phase 400 V										
Inverter model CIMR-VC4A		0001	0002	0004	0005	0007	0009	0011	0018	0023	0031	0038
Inverter output	Motor output kW at normal duty*2	0.37	0.75	1.5	2.2	3.0	4.0	5.5	7.5	11	15.0	18.5
	Motor output kW at heavy duty*2	0.18	0.37	0.75	1.5	2.2	3.0	4.0	5.5	7.5	11.0	15.0
	Rated output current at normal duty [A]*3	1.2	2.1	4.1	5.4	6.9	8.8	11.1	17.5	23.0	31.0	38.0
	Rated output current at heavy duty [A]*5	1.2	1.8	3.4	4.8	5.5	7.2	9.2	14.8	18.0	24.0	31.0
	Overload	120% for 60 sec at normal duty, 150% for 60 sec at heavy duty from inverter rated output current										
	Rated output power at normal duty [kVA]*	0.9	1.6	3.1	4.1	5.3	6.7	8.5	13.3	17.5	23.6	29.0
	Rated output power at heavy duty [kVA]*	0.9	1.4	2.6	3.7	4.2	5.5	7.0	11.3	13.7	18.3	23.6
Max. output voltage	Three-phase 380 to 480 V (proportional to input voltage)											
Max. output frequency	400 Hz											
Inverter input	Rated input voltage	Three-phase 380 to 480 V, -15% to +10%										
	Rated input frequency	50/60 Hz, ±5%										

* based on input voltage 400 V

*1 Drives with a single-phase power supply input have three-phase output. Single-phase motors cannot be used.

*2 The motor capacity (kW) refers to a YASKAWA 4-pole, 60 Hz, 200 V motor. The rated output current of the drive output amps should be equal to or greater than the motor rated current.

*3 at 2 kHz carrier frequency without derating

*4 at 10 kHz carrier frequency without derating

*5 at 8 kHz carrier frequency without derating

*6 only heavy duty available



Rotational Auto-Tuning must be performed to achieve the performance described with Open Loop Vector Control.

		Specifications
Control Functions	Control methods	Open Loop Vector Control (Current Vector), V/f Control, PM Open Loop Vector Control (for SPM and IPM motors)
	Frequency Control Range	0.01 to 400 Hz
	Frequency Accuracy (Temperature Fluctuation)	Digital input: within $\pm 0.01\%$ of the max. output frequency (-10 to $+50^{\circ}\text{C}$) Analog input: within $\pm 0.1\%$ of the max. output frequency ($25^{\circ}\text{C} \pm 10^{\circ}\text{C}$)
	Frequency Setting Resolution	Digital input: 0.01 Hz Analog input: 1/1000 of max. frequency
	Output Frequency Resolution	20 bit of maximum output frequency (parameter E1-04 setting)
	Frequency Setting Resolution	Main frequency reference: 0..10 V (20 k Ω) 10 bit, 4..20 mA (250 Ω) or 0..20 mA (250 Ω) 9-bit Main speed reference : Pulse Train Input (max. 32 kHz)
	Starting Torque	200% / 0.5 Hz (assumes Heavy Duty rating AC Motor of 3.7 kW or less using Open Loop Vector Control), 50% / 6 Hz (assumes PM Open Loop Vector Control)
	Speed Control Range	1:100 (Open Loop Vector Control), 1:20 to 40 (V/f Control), 1:10 (PM Open Loop Vector Control)
	Speed Control Accuracy	$\pm 0.2\%$ in Open Loop Vector Control ($25^{\circ}\text{C} \pm 10^{\circ}\text{C}$) *1
	Speed Response	5 Hz in Open Loop Vector ($25^{\circ}\text{C} \pm 10^{\circ}\text{C}$) (excludes temperature fluctuation when performing Rotational Auto-Tuning)
	Torque Limit	Open Loop Vector Control allows separate settings in four quadrants
	Accel/Decel Time	0.0 to 6000.0 s (4 selectable combinations of independent acceleration and deceleration settings)
Braking Torque	① Short-time decel torque*2: over 150% for 0.1/0.2 kW motors, over 100% for 0.4/ 0.75 kW motors, over 50% for 1.5 kW motors, and over 20% for 2.2 kW and above motors (overexcitation braking/High-Slip Braking: approx. 40%) ② Continuous regen. torque: approx. 20% (approx. 125% with dynamic braking resistor option*3: 10% ED, 10 s, internal braking transistor)	
V/f Characteristics	User-selected programs, V/f preset patterns possible	
Main Control Functions	Momentary power loss ride-thru, Speed search, Overtorque detection, Torque limit, 17-step speed (max), Accel/decel time switch, S-curve accel/decel, 3-wire sequence, Auto-tuning (rotational, stationary tuning for resistance between lines), Dwell, Cooling fan on/off switch, Slip compensation, Torque compensation, Frequency jump, Upper/lower limits for frequency reference, DC injection braking at start and stop, Overexcitation braking, High slip braking, PID control (with sleep function), Energy saving control, MEMOBUS comm. (RS-485/422 max, 115.2 kbps), Fault restart, Application presets, DriveWorksEZ (customized function), Removable terminal block with parameter backup function...	
Protection Function	Motor Protection	Motor overheat protection based on output current
	Momentary Overcurrent Protection	Drive stops when output current exceeds 200% of Heavy Duty Rating
	Overload Protection	Drive stops after 60 s at 150% of rated output current (Heavy Duty Rating)*4
	Overvoltage Protection	200 V class: Stops when DC bus exceeds approx. 410 V 400 V class: Stops when DC bus exceeds approx. 820 V
	Undervoltage Protection	Stops when DC bus voltage falls below the following levels: Three-phase 200 V class: approx. 190 V, single-phase 200 V class: approx. 160 V, three-phase 400 V class: approx. 380 V, three-phase 380 V class: approx. 350 V
	Momentary Power Loss Ride-Thru	Stops after approx. 15 ms (default). Parameter settings allow the drive to continue running if power loss lasts for up to approx. 2 s *5
	Heatsink Overheat Protection	Protection by thermistor
	Braking Resistance Overheat Protection	Overheat sensor for braking resistor (optional ERF-type, 3% ED)
	Stall Prevention	Separate settings allowed during acceleration, and during run. Enable/disable only during deceleration.
Operating Environment	Ground Fault Protection	Protection by electronic circuit *6
	Charge LED	Charge LED remains lit until DC bus has fallen below approx. 50 V
	Area of Use	Indoors
	Ambient Temperature	-10 to $+50^{\circ}\text{C}$ (open chassis), -10 to $+40^{\circ}\text{C}$ (NEMA Type 1)
	Humidity	95 RH% or less (no condensation)
	Storage Temperature	-20 to $+60^{\circ}\text{C}$ (short-term temperature during transportation)
	Altitude	Max. 1000 m (output derating of 1% per 100 m above 1000 m, max. 3000 m)
Shock	10 to less than 20 Hz (9.8 m/s ²) max., 20 to 55 Hz (5.9 m/s ²) max.	
Safety Standard	UL508C, EN954-1 Cat. 3, IEC/EN61508 SIL2	
Protection Design	IP20 open-chassis, NEMA Type 1 enclosure	

*1 Speed control accuracy may vary slightly depending on installation conditions or motor used.

*2 Momentary average deceleration torque refers to the deceleration torque from 60Hz down to 0 Hz. This may vary depending on the motor.

*3 If L3-04 is enabled when using a braking resistor or braking resistor unit, the motor may not stop within the specified deceleration time.

*4 Overload protection may be triggered at lower levels if output frequency is below 6 Hz.

*5 Varies by drive capacity. Drives smaller than 7.5 kW (CIMR-VA2A0004/CIMR-VA4A0023) require a separate Momentary Power Loss Recovery Unit to continue operating during a momentary power loss of 2 s.

*6 Protection may not be provided under the following conditions as the motor windings are grounded internally during run:

- Low resistance to ground from the motor cable or terminal block.
- Drive already has a short-circuit when the power is turned on.



Connection Diagram

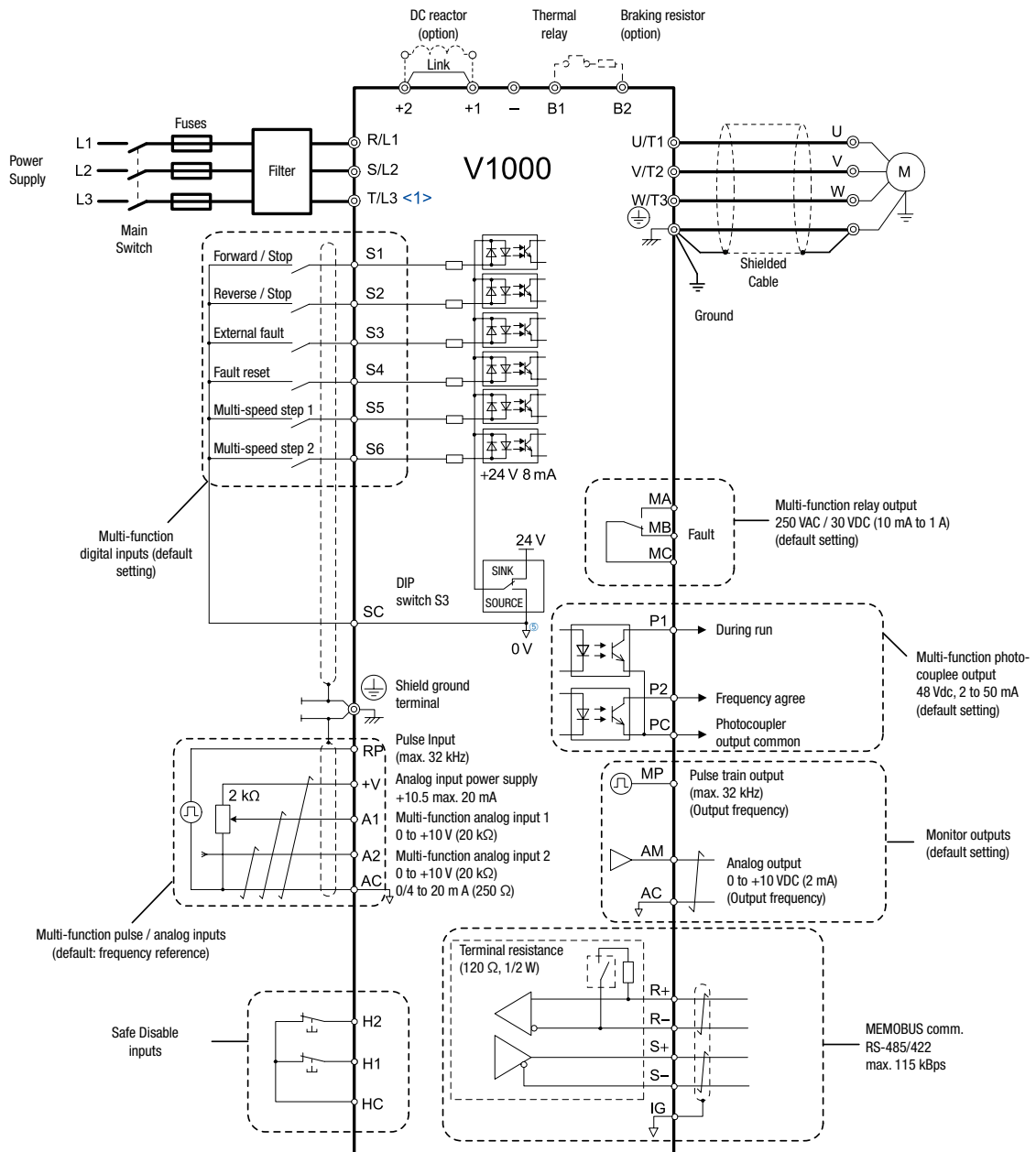

- ± Use twisted pair cables.
- ⊕ Use shielded twisted pair cables.
- ⊙ Indicates a main circuit terminal.
- Indicates a control circuit terminal.



V1000 Dimensions

IP20/Open-Chassis (without an EMC filter)

Voltage Class	Drive Model CIMR-VC□	Dimensions in mm									Weight (kg)
		W1	H1	W	H	D	t1	H2	D1		
Single-Phase 200 V Class	BA0001B	56	118	68	128	76	3	5	6.5	0.6	
	BA0002B	56	118	68	128	76	3	5	6.5	0.6	
	BA0003B	56	118	68	128	118	5	5	38.5	1.0	
Three-Phase 200 V Class	2A0001B	56	118	68	128	76	3	5	6.5	0.6	
	2A0002B	56	118	68	128	76	3	5	6.5	0.6	
	2A0004B	56	118	68	128	108	5	5	38.5	0.9	
	2A0006B	56	118	68	128	128	5	5	58.5	1.1	

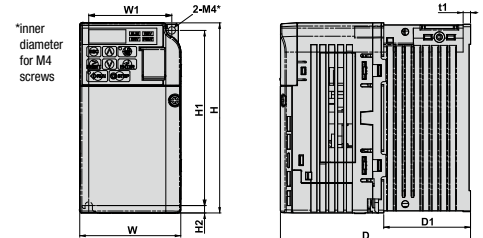

Voltage Class	Drive Model CIMR-VC□	Dimensions in mm									Weight (kg)
		W1	H1	W	H	D	t1	H2	D1		
Single-Phase 200 V Class	BA0006B	96	118	108	128	137.5	5	5	58	1.7	
	BA0010B	96	118	108	128	154	5	5	58	1.8	
	BA0012B	128	118	140	128	163	5	5	65	2.4	
	BA0018B	158	118	170	128	180	5	5	65	3.0	
Three-Phase 200 V Class	2A0010B	96	118	108	128	129	5	5	58	1.7	
	2A0012B	96	118	108	128	137.5	5	5	58	1.7	
	2A0020B	128	118	140	128	143	5	5	65	2.4	
Three-Phase 400 V Class	4A0001B	96	118	108	128	81	5	5	10	1.0	
	4A0002B	96	118	108	128	99	5	5	28	1.2	
	4A0004B	96	118	108	128	137.5	5	5	58	1.7	
	4A0005B	96	118	108	128	154	5	5	58	1.7	
	4A0007B	96	118	108	128	154	5	5	58	1.7	
	4A0009B	96	118	108	128	154	5	5	58	1.7	
	4A0011B	128	118	140	128	143	5	5	65	2.4	

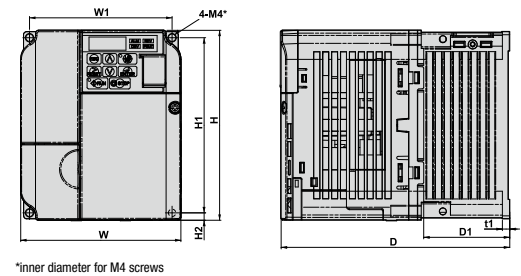

IP20/NEMA Type 1 (without an EMC filter)

Voltage Class	Drive Model CIMR-VC□	Dimensions in mm												Weight (kg)
		W1	H2	W	H1	D	t1	H5	D1	H	H4	H3	H6	
Single-Phase 200 V Class	BA0001F	56	118	68	128	76	3	5	6.5	149.5	20	4	1.5	0.8
	BA0002F	56	118	68	128	76	3	5	6.5	149.5	20	4	1.5	0.8
	BA0003F	56	118	68	128	118	5	5	39	149.5	20	4	1.5	1.2
Three-Phase 200 V Class	2A0001F	56	118	68	128	76	3	5	6.5	149.5	20	4	1.5	0.8
	2A0002F	56	118	68	128	76	3	5	6.5	149.5	20	4	1.5	0.8
	2A0004F	56	118	68	128	108	5	5	39	149.5	20	4	1.5	1.1
	2A0006F	56	118	68	128	128	5	5	59	149.5	20	4	1.5	1.3

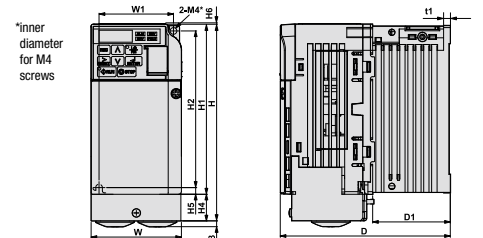

Voltage Class	Drive Model CIMR-VC□	Dimensions in mm												Weight (kg)
		W1	H2	W	H1	D	t1	H5	D1	H	H4	H3	H6	
Single-Phase 200 V Class	BA0006F	96	118	108	128	137.5	5	5	58	149.5	20	4	1.5	1.9
	BA0010F	96	118	108	128	154	5	5	58	149.5	20	4	1.5	2.0
	BA0012F	128	118	140	128	163	5	5	65	153	20	4.8	5	2.6
	BA0018F	158	118	170	128	180	5	5	65	171	38	4.8	5	3.3
Three-Phase 200 V Class	2A0010F	96	118	108	128	129	5	5	58	149.5	20	4	1.5	1.9
	2A0012F	96	118	108	128	137.5	5	5	58	149.5	20	4	1.5	1.9
	2A0020F	128	118	140	128	143	5	5	65	153	20	4.8	5	2.6
Three-Phase 400 V Class	4A0001F	96	118	108	128	81	5	5	10	149.5	20	4	1.5	1.2
	4A0002F	96	118	108	128	99	5	5	28	149.5	20	4	1.5	1.4
	4A0004F	96	118	108	128	137.5	5	5	58	149.5	20	4	1.5	1.9
	4A0005F	96	118	108	128	154	5	5	58	149.5	20	4	1.5	1.9
	4A0007F	96	118	108	128	154	5	5	58	149.5	20	4	1.5	1.9
	4A0009F	96	118	108	128	154	5	5	58	149.5	20	4	1.5	1.9
	4A0011F	128	118	140	128	143	5	5	65	153	20	4.8	5	2.6

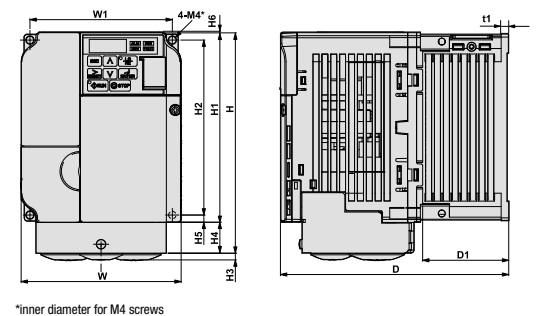

Voltage Class	Drive Model CIMR-VC□	Dimensions in mm												Weight (kg)	
		W1	H2	W	H1	D	t1	H5	D1	H	H4	H3	H6		d
Three-Phase 200 V Class	2A0030F	122	248	140	234	140	5	13	55	254	13	6	1.5	M5	3.8
	2A0040F	122	248	140	234	140	5	13	55	254	13	6	1.5	M5	3.8
	2A0056F	160	284	180	270	163	5	13	75	290	15	6	1.5	M5	5.5
	2A0069F	192	336	220	320	187	5	22	78	350	15	7	1.5	M6	9.2
Three-Phase 400 V Class	4A0018F	122	248	140	234	140	5	13	55	254	13	6	1.5	M5	3.8
	4A0023F	122	248	140	234	140	5	13	55	254	13	6	1.5	M5	3.8
	4A0031F	160	284	180	270	143	5	13	55	290	15	6	1.5	M5	5.2
	4A0038F	160	284	180	270	163	5	13	75	290	13	6	1.5	M5	5.5

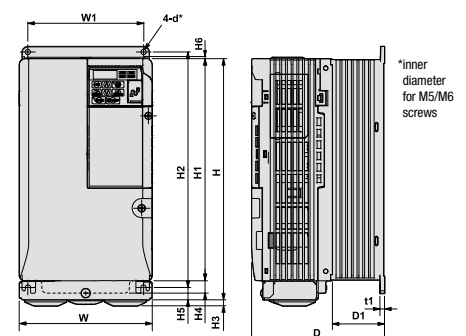

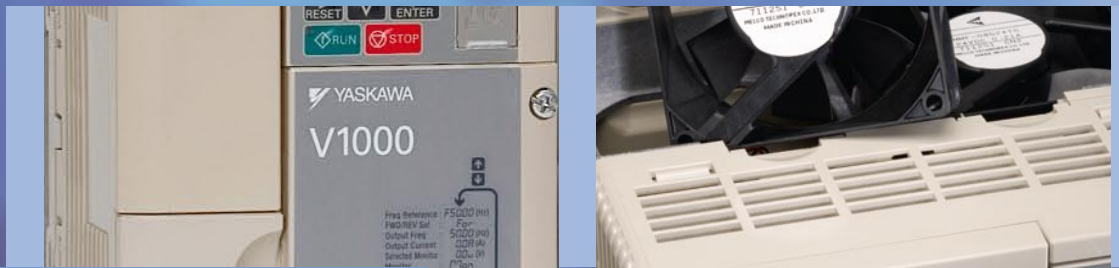

V1000 Finless Version Dimensions

... for Models BA0001~2A0006

Voltage Class	Drive Model CIMR-VC□	Dimensions in mm							
		W	H	D	W1	H1	H2	t1	Weight (kg)
Single-Phase 200 V Class	BA0001	68	128	71	56	118	5	3	0.6
	BA0002	68	128	71	56	118	5	3	0.6
	BA0003	68	128	81	56	118	5	3	0.8
Three-Phase 200 V Class	2A0001	68	128	71	56	118	5	3	0.6
	2A0002	68	128	71	56	118	5	3	0.6
	2A0004	68	128	71	56	118	5	3	0.7
	2A0006	68	128	71	56	118	5	3	0.7

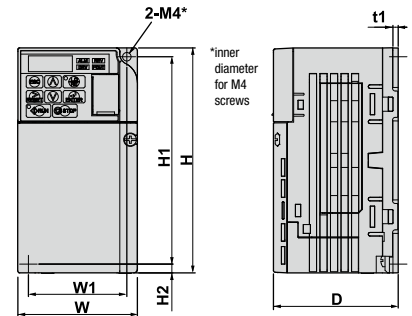

... for Models BA0006~4A0009

Voltage Class	Drive Model CIMR-VC□	Dimensions in mm							
		W	H	D	W1	H1	H2	t1	Weight (kg)
Single-Phase 200 V Class	BA0006	108	128	79.5	96	118	5	4	1.1
	BA0010	108	128	91	96	118	5	4	1.1
Three-Phase 200 V Class	2A0008	108	128	71	96	118	5	4	1.0
	2A0010	108	128	71	96	118	5	4	1.0
	2A0012	108	128	79.5	96	118	5	4	1.0
Three-Phase 400 V class	4A0001	108	128	71	96	118	5	4	0.9
	4A0002	108	128	71	96	118	5	4	0.9
	4A0004	108	128	79.5	96	118	5	4	1.0
	4A0005	108	128	96	96	118	5	4	1.0
	4A0007	108	128	96	96	118	5	4	1.1
	4A0009	108	128	96	96	118	5	4	1.1

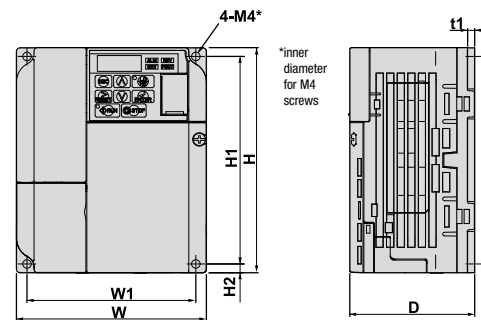

... for Models BA0012~4A0011

Voltage Class	Drive Model CIMR-VC□	Dimensions in mm							
		W	H	D	W1	H1	H2	t1	Weight (kg)
Single-Phase 200 V Class	BA0012	140	128	98	128	118	5	4	1.4
Three-Phase 200 V Class	2A0018	140	128	78	128	118	5	4	1.3
	2A0020	140	128	78	128	118	5	4	1.3
Three-Phase 400 V class	4A0011	140	128	78	128	118	5	4	1.3

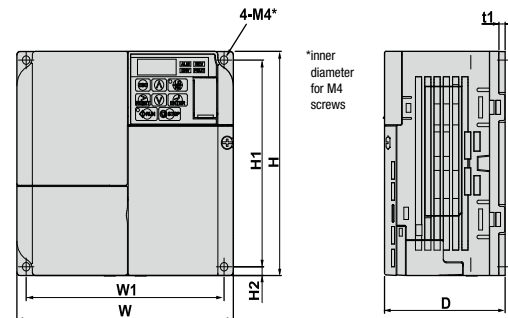

... for Models 2A0030~4A0038

Voltage Class	Drive Model CIMR-VC□	Dimensions in mm											
		W	H	D	W1	H1	H2	H3	H4	H5	d	t1	Weight (kg)
Three-Phase 200 V Class	2A0030	140	260	145	122	248	6	234	13	5	M5	5	3.2
	2A0040	140	260	145	122	248	6	234	13	5	M5	5	3.2
	2A0056	180	300	147	160	284	8	270	15	5	M5	5	4.6
	2A0069	220	350	152	192	336	7	320	15	5	M6	5	7.0
Three-Phase 400 V Class	4A0018	140	260	145	122	248	6	234	13	5	M5	5	3.1
	4A0023	140	260	145	122	248	6	234	13	5	M5	5	3.2
	4A0031	180	300	147	160	284	8	270	15	5	M5	5	4.3
	4A0038	180	300	147	160	284	8	270	15	5	M5	5	4.6

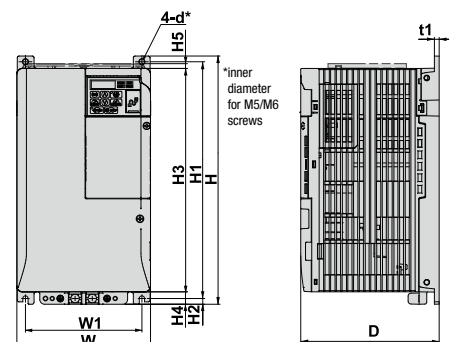

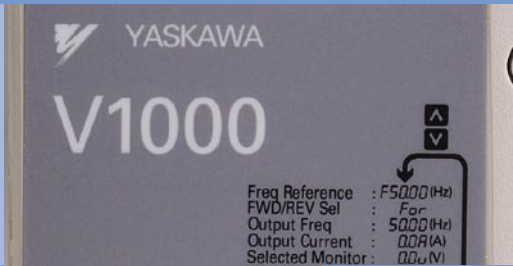

V1000 IP66 Dimensions

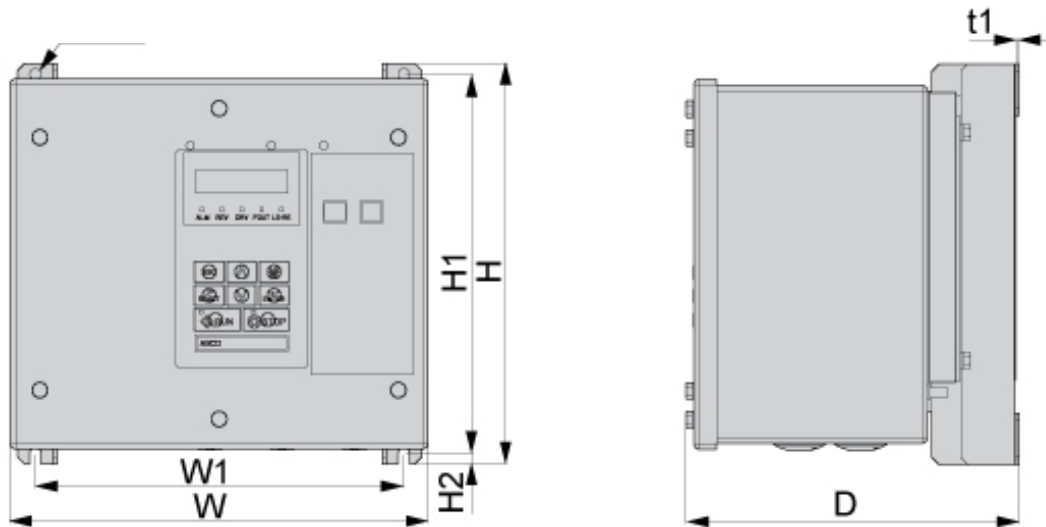

Inverter model VC	Dimensions in mm							Weight (kg)
	W	H	D	W1	H1	H2	t1	
BA0001HAA	232	222	185	204.5	210	6	2	5.6
BA0002HAA	232	222	185	204.5	210	6	2	5.6
BA0003HAA	232	222	185	204.5	210	6	2	5.8
BA0006HAA	257	255	235	227.5	241	7	2	8.0
BA0010HAA	257	255	235	227.5	241	7	2	8.0
BA0012HAA	257	255	235	227.5	241	7	2	8.3
2A0001HAA	232	222	185	204.5	210	6	2	5.6
2A0002HAA	232	222	185	204.5	210	6	2	5.6
2A0004HAA	232	222	185	204.5	210	6	2	5.7
2A0006HAA	232	222	185	204.5	210	6	2	5.7
2A0010HAA	257	255	235	227.5	241	7	2	7.9
2A0012HAA	257	255	235	227.5	241	7	2	7.9
2A0020HAA	257	255	235	227.5	241	7	2.5	9.2
2A0030HAA	385	420	305	360	400	8.5	2.5	28.1
2A0040HAA	385	420	305	360	400	8.5	2.5	28.1
4A0001HAA	232	222	185	204.5	210	6	2	5.9
4A0002HAA	232	222	185	204.5	210	6	2	5.9
4A0004HAA	232	222	185	204.5	210	6	2	6.0
4A0005HAA	257	255	235	227.5	241	7	2.5	8.9
4A0007HAA	257	255	235	227.5	241	7	2.5	8.9
4A0009HAA	257	255	235	227.5	241	7	2.5	8.9
4A0011HAA	257	255	235	227.5	241	7	2.5	9.2
4A0018HAA	385	420	305	360	400	8.5	2.5	27.9
4A0023HAA	385	420	305	360	400	8.5	2.5	28.0
4A0031HAA	385	420	305	360	400	8.5	2.5	29.1
4A0038HAA	385	420	305	360	400	8.5	2.5	29.4

Data and Dimensions are preliminary and subject to be changed at any time.

Options

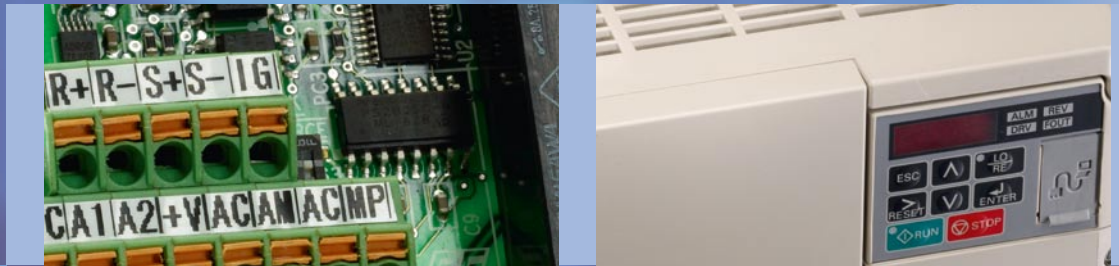

Name	Purpose	Model, Manufacturer
Input noise filter	Reduces noise from the line that enters into the drive input power system. Should be installed as close as possible to the drive.	FS23638-□□□□ (Single-Phase 200 V) FS23637-□□□□ (Three-Phase 200 V) FS23639-□□□□ (Three Phase 400 V)
Braking resistor	Used to shorten the deceleration time by dissipating regenerative energy through a resistor (3% ED).	ERF-150WJ series
Braking resistor unit	Used to shorten the deceleration time by dissipating regenerative energy through a resistor. A thermal overload relay is built in (10% ED).	LKEB series
24 V power supply	Provides power supply for the control circuit and option boards. Note: Parameter settings cannot be changed when the drive is operating solely from this power supply.	PS-V10S PS-V10M
USB copy unit (RJ-45/USB compatible plug)	Adapter for connecting the drive to the USB port of a PC. (e.g. for Support Tool Drive Wizard Plus) Can copy parameter settings to be later transferred to another drive.	JVOP-181
Support tools (DriveWizard Plus) cable	Connects the drive to a PC for use with DriveWizard.	WV103
LCD operator	For easier operation when using the optional LCD operator. Allows for remote operation. Includes a Copy function for saving drive settings.	JVOP-180
LCD operator extension cable	Cable for connecting the LCD operator.	WV001: 1 m WV003: 3 m
Communication interface unit	MECHATROLINK-2	Available soon
	CC-link	SI-C3/V
	DeviceNet	SI-N3/V
	PROFIBUS-DP	SI-P3/V
	CANopen	SI-S3/V
LONWORKS	Available soon	
Momentary power loss recovery unit	Ensures continued drive operation for a power loss of up to 2 s.	P0010 type (200 V class) P0020 type (400 V class)
Attachment for external heatsink	Mechanical kit to install the drive with the heatsink out of the cabinet. Note: current derating must be considered when this installation method is used.	(Please contact your YASKAWA representative)
Screw-type terminal board	Control terminal board with screw-type terminals.	Available soon
Plus operator mounting kit	For the use with holes through the panel.	100-039-992
	For the use with panel mounted threaded studs.	100-039-993

Note: contact the manufacturer in question for availability and specifications of non-YASKAWA products.

Ratings & Type Descriptions

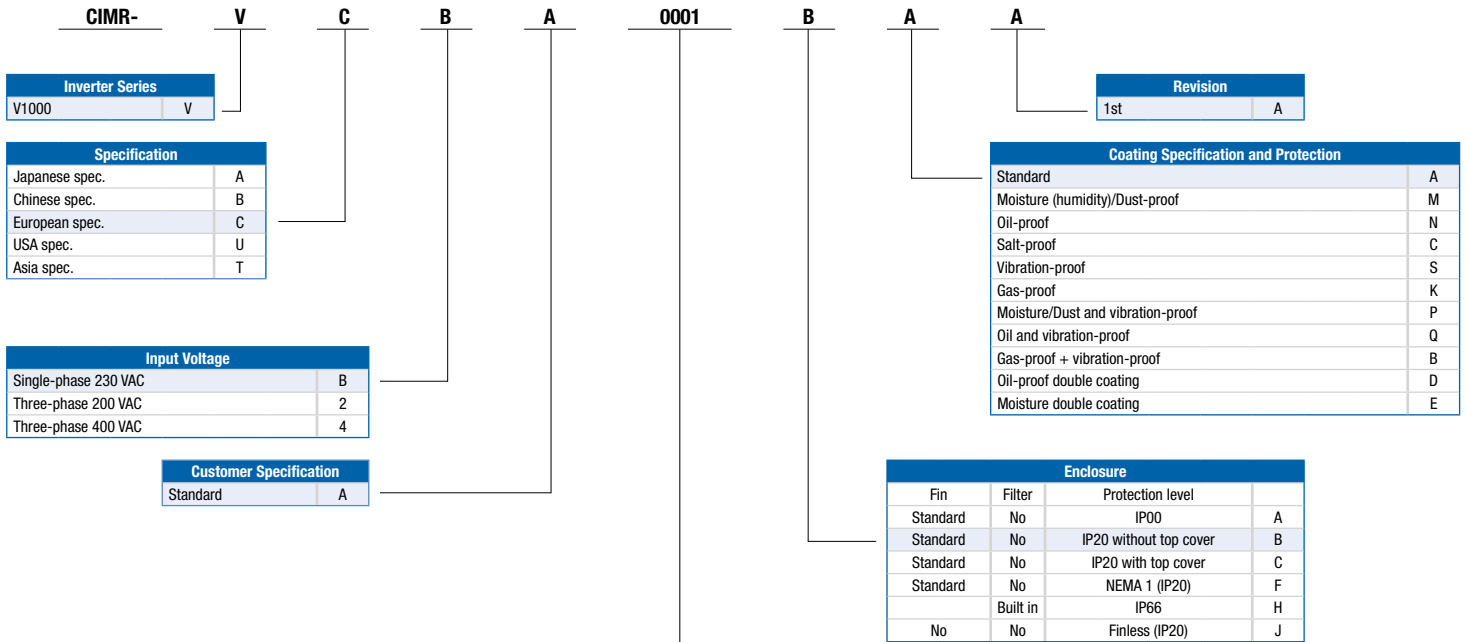

Single-phase 230 VAC				
	Normal duty		Heavy duty	
	Rated output current	Max. applicable motor	Rated output current	Max. applicable motor
0001	1.2 A	0.18 kW	0.8 A	0.1 kW
0002	1.9 A	0.37 kW	1.6 A	0.18 kW
0003	3.3 A	0.75 kW	3.0 A	0.55 kW
0006	6.0 A	1.1 kW	5.0 A	0.75 kW
0010	9.6 A	2.2 kW	8.0 A	1.5 kW
0012	12.0 A	3.0 kW	11.0 A	2.2 kW
0018	-	-	17.5 A	4.0 kW

Three-phase 200 VAC				
	Normal duty		Heavy duty	
	Rated output current	Max. applicable motor	Rated output current	Max. applicable motor
0001	1.2 A	0.4 kW	0.8 A	0.1 kW
0002	1.9 A	0.37 kW	1.6 A	0.2 kW
0004	3.5 A	0.75 kW	3.0 A	0.4 kW
0006	6.0 A	1.1 kW	5.0 A	0.75 kW
0010	9.6 A	2.2 kW	8.0 A	1.5 kW
0012	12.0 A	3.0 kW	11.0 A	2.2 kW
0020	19.6 A	5.5 kW	17.5 A	4.0 kW
0030	30.0 A	7.5 kW	25.0 A	5.5 kW
0040	40.0 A	11.0 kW	33.0 A	7.5 kW
0056	56.0 A	15.0 kW	47.0 A	11.0 kW
0069	69.0 A	18.5 kW	60.0 A	15.0 kW

Three-phase 400 VAC				
	Normal duty		Heavy duty	
	Rated output current	Max. applicable motor	Rated output current	Max. applicable motor
0001	1.2 A	0.37 kW	1.2 A	0.2 kW
0002	2.1 A	0.75 kW	1.8 A	0.4 kW
0004	4.1 A	1.5 kW	3.4 A	0.75 kW
0005	5.4 A	2.2 kW	4.8 A	1.5 kW
0007	6.9 A	3.0 kW	5.5 A	2.2 kW
0009	8.8 A	4.0 kW	7.2 A	3.0 kW
0011	11.1 A	5.5 kW	9.2 A	4.0 kW
0018	17.5 A	7.5 kW	14.8 A	5.5 kW
0023	23.0 A	11.0 kW	18.0 A	7.5 kW
0031	31.0 A	15.0 kW	24.0 A	11.0 kW
0038	38.0 A	18.5 kW	31.0 A	15.0 kW



YASKAWA Electric Europe GmbH

Hauptstr. 185
65760 Eschborn
Deutschland / Germany

+49 6196 569-300
info@yaskawa.de
www.yaskawa.eu.com

International Standards



Safety Standards

Safety Stop

RoHS Directive

RoHS Directive Stands for the EU directive on the Restriction of the Use of Certain Hazardous Substances in Electrical and Electronic Equipment